

Pedestal and Dual-T Head Instructions

- Step 1. Adjust the angle of the arm by loosening the adjustment knob (D).
- Step 2. Adjust the angle and rotation of the pedestal head by loosening the swivel-tightening knob (E).
- Step 3. Attach the PSP cradle to the dual-T tab head (F) by inserting the T-tabs into the T-slots (G).

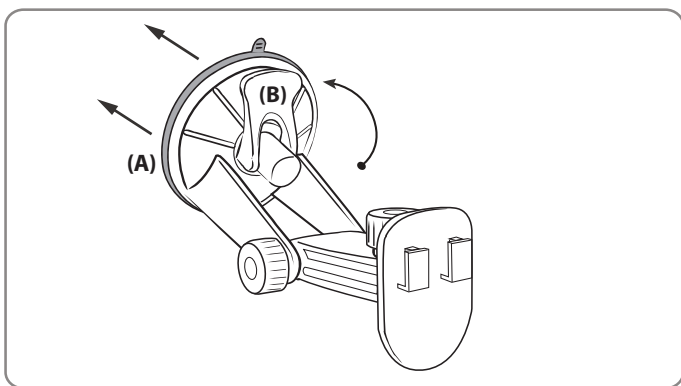

Windshield Installation

- Step 1. Push the pedestal suction cup (A) firmly to the windshield. Flip the lever (B) down to secure the suction cup.

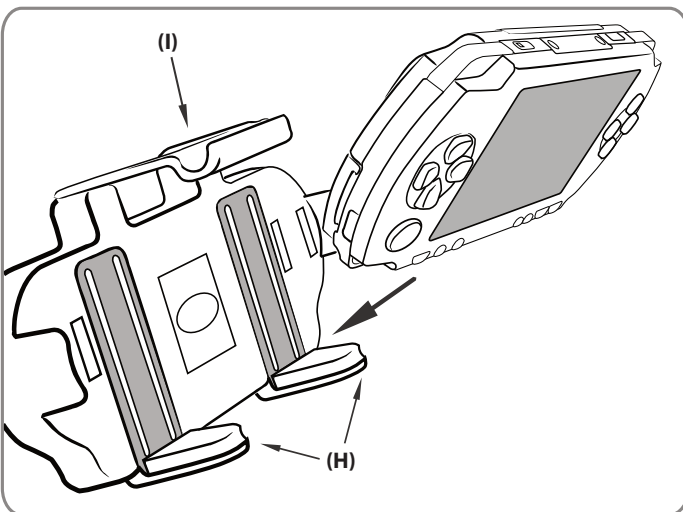

Sony PSP Cradle Instructions

- Step 1. Insert PSP into the cradle at a slant so that the base of the PSP comes to rest on the spring loaded support legs (H).
- Step 2. While firmly holding the cradle, push downward on the PSP so that the spring loaded support legs slide down. This allows enough clearance for the top of the PSP to slide under the top support clip (I).
- Step 3. To remove PSP from cradle follow step 2

Dash Installation

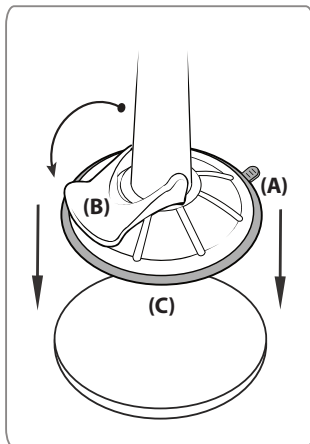

- Step 1. Locate a safe flat surface on the dash or console to mount the pedestal. Clean the dash with the alcohol pad provided. Let the dash surface dry before applying the adhesive disc (C).
- Step 2. Push the pedestal suction cup (A) firmly to the disc (C). Flip the lever (B) down to secure the suction cup.

Safety Precautions

Do not install Arkon products over an air bag cover or within the air bag deployment zone. Arkon Resources, Inc. assumes no responsibility of liability for injury or death as a result of car crashes and/or air bag deployment.

Arkon Resources, Inc. is not responsible for any damages caused to your car, your device, or yourself due to the installation or use of the pedestal mount.



The Mobile Mounting Specialists™

Consumer Hotline:

(USA) (800) 841-0884

(INT'L) (626) 254-9005

Mon-Fri. 9am-5pm, PST © Copyright 2007 Arkon Resources, Inc.

www.arkon.com

Arcadia, CA 91006 USA

Made in Taiwan

PSP is a trademark of Sony Computer Entertainment Inc. Arkon Resources, Inc. is not affiliated with Sony Computer Entertainment Inc.